

4 HIGH SOCIETY R40 · 4/4L

John Brenchley: RSCDS XLVI 8 · Crib: E-cribs · Diagram: Keith Rose's Diagrams

On 2nd chord, 2c+4c cross (1,2x,3,4x)

- 1- Parallel Reels4 on the sides, on [8] mid Cs do not pass but pivot R to face end Cs (1,3,2x,4x)
- 9- 1c+3c & 2c+4c R&L start on sides, 3c+2c finish in middle BHJ
- 17- 3c+2c Poussette (1,2x,3,4x)
- 25- 2c & 3c ½ Fig8 round end C (1,2,3x,4x) ; All turn P RH and face end (1c+2c face up, 3c+4c down)
- 33- 1c+2c & 3c+4c Interlocking Allemandes: the mid couples pass each other to finish (2,4x,1,3x)

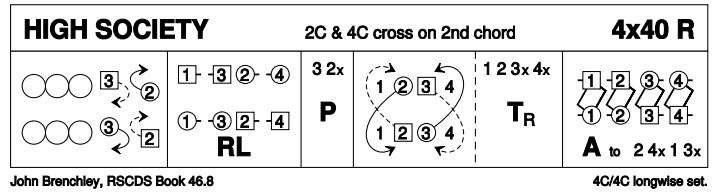

5 PANOT DE FLOR J32 · 3/4L

Murrough Landon: Woodhall Book 5 · Crib: E-cribs · Diagram: Keith Rose's Diagrams

- 1- 1c turn RH | cast off (2c up) ; 2c+1W & 1M+3c RHA, 1c pass RSh
- 9- 2c+1M & 1W+3c LHA, 1c end RSh to P on midline ; 1c turn 1¼ RH to face 2pl opp side
- 17- 1c dance LSh round 2cnrs **while{4}** cnrs A&R diagonally, touching NH in a circle ; 1c repeat RSh round 1cnrs & cross to 2pl **while{4}** cnrs again A&R (2,1,3). *NB 1c's loops on the diagonals are similar to Fig8 on the sides*
- 25- Circle6 to L & back (2,1,3)

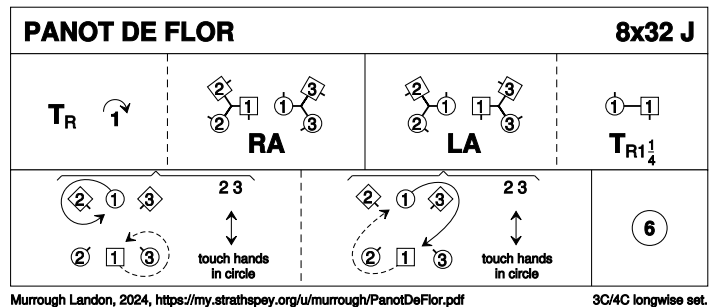

6 MO SASSENACH BHÒIDHEACH S32 · 3/3L

Maria Elena Bonacini · Crib: E-cribs

- 1- 1c set | turn BH ; dance down | cast up behind 2c
- 9- 1c+2c Knot, 1c face 1cnrs
- 17- 1c+1cnrs Corners Pass & Turn BH ; 1c repeat with 2cnrs to own sides (2,1,3)
- 25- 1c+3c ½ Poussette (starting from sides) | **while{4}** 2c set | turn BH, all stay in centre ; all set | cast to own sides (2,3,1)

7 ON THE TROPIC OF CAPRICORN J32 · 3/4L

Jim Stott: The Argentine Collection 2020 · Crib: E-cribs · Diagram: Keith Rose's Diagrams

- 1- 1c set | cast off (2c up) ; lead down, cross | cast to 2pl (2,1x,3)
- 9- All set | turn P BH ½ (PdB) ; 1c dance in towards P, pivot R into facing lines3 across, 1M between 2c, 1W between 3c
- 17- All set | turn opposite person BH ½ (PdB) ; 1c dance in towards P, pivot R to 2pl (3x,1,2x)
- 25- 1c A&R **while{4}** cnrs chase clw ½ ; all turn P RH (2,1,3)

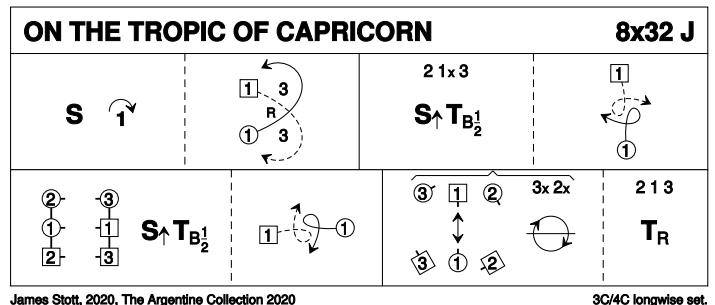

8 TRIP TO TIMBER RIDGE R32 · 3/4L

Linda Henderson: RSCDS LII 12 · Crib: E-cribs · Diagram: Keith Rose's Diagrams

- 1- 1c turn RH | cast (2c up) ; 1W+2c & 1M+3c RHA, 1c facing 1cnrs at end
- 9- Corners Pass and Turn, on [16] 1c pull Rsh back to finish BtoB in centre facing opposite side
- 17- DTr, on [23-24] 1c Petronella turn to 2pl (2,1,3)
- 25- Circle6 and back

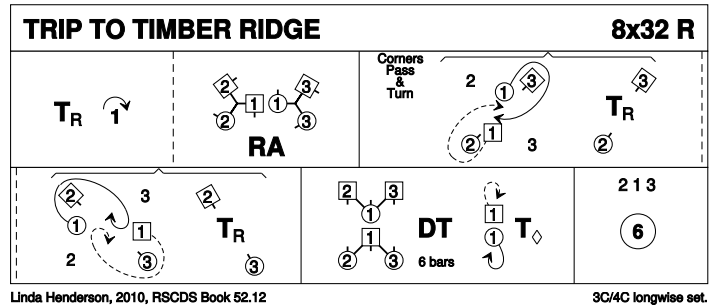

PROGRAMME ITEM – break

9 THE YORKSHIRE ROSE J32 · 3/4L

Trish Reid: RSCDS LIV 1 · Crib: MiniCribs · Diagram: Keith Rose's Diagrams

- 1-8 1s+2s+3s set & cross RH, repeat back to places
- 9-16 1s lead down the middle then lead up to 2nd places (2s step up 11-12)
- 17-24 2s+1s turn (Men RH, Ladies LH), 1s+3s turn (Men LH, Ladies RH)
- 25-32 2s+1s+3s dance reflection reels of 3 on sides with 1s out/up, 2s in/down down to start (2nd time through the 1s continue the reel into 4th place)

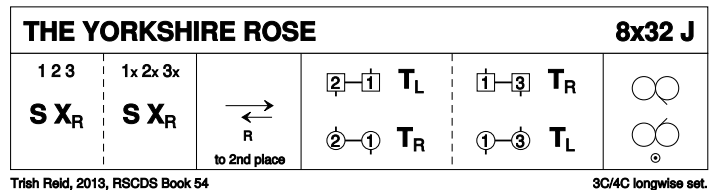

10 2121AU R32 · 3/4L

Bill Unger · Crib: E-cribs · Diagram: Keith Rose's Diagrams

- 1- 1c cross RH | cast off (2c up) ; turn RH to 2plx and face clw (2,1x,3)
- 9- 1c chase clw round the set to 2plx **while(8)** 1cnrs cross RH | loop R to face in ; cross back RH | loop R to face in **while(8)** 2cnrs stand still | cross RH ; loop R to face in | cross back RH (2,1x,3)
- 17- All set | 1c turn RH $\frac{3}{4}$ into facing lines3 across ; all set | 1c turn RH $\frac{3}{4}$ to 2pl (2,1,3)
- 25- Circle6 and back (2,1,3)

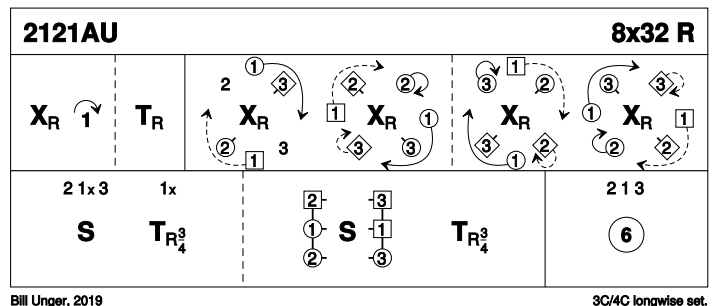

11 LE PHARE DE CORDOUAN S32 · 3/3L

Danièle Landrieau: *The Paris Book of Scottish Country Dances, volume 2* · Crib: E-cribs · Diagram: Keith Rose's Diagrams

- 1- 1c turn BH and face up NHJ | cast off (2c up) ; cross down RH between 3c and cast up to face 1cnrs
- 9- Corners Pass and Turn BH, finishing on opposite sides (2,1x,3)
- 17- 1c dance up | cast off ; 1c turn P RH ½, face P | cast R to exchanged places (2,1,3)
- 25- 1c+3c The Tourbillon (2,3,1)

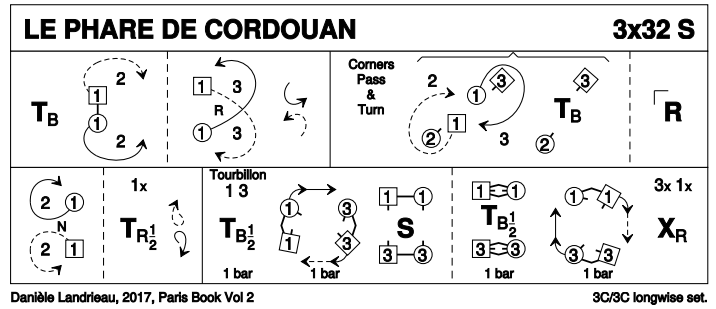

12 FLIGHT TO MELBOURNE R32 · 4S

Shirley Campbell: *RSCDS XLVII 3* · Crib: E-cribs · Diagram: Keith Rose's Diagrams

- 1- 1M+3W (and 1W+3M) Fig 8 round 2c (4c) (W crossing in front of M), to own places
- 9- 1c & 3c in promhold Rsh Reels3 across with the nearest members of 2c & 4c, to places.
- 17- All C S&Link (to face P) ; turn RH ½ | chase 1 place clw. (4,1,2,3)
- 25- All Circle8 and back (4,1,2,3)

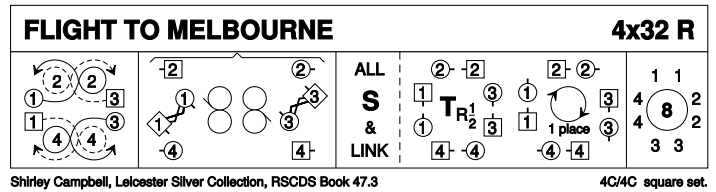

13 THE SHETLAND SHEPHERDESS J32 · 3/4L

Ron Wallace: *A Third Book of Graded Scottish Country Dances* · Crib: E-cribs · Diagram: Keith Rose's Diagrams

- 1- 1c dance between 2c and cast up to place ; dance ½ Fig8 round 2c (1x,2,3)
- 9- 1c cross down into mirror Reels3 on own side, 2c starting out and up (1,2,3)
- 17- 1c (start inwards) change place with 2c EH and face out | 1c turn 3c EH to face up in the middle ; 1c dance to top and cast off (2,1,3)
- 25- All A&R and clap on last beat of [28] ; All turn P RH (2,1,3)

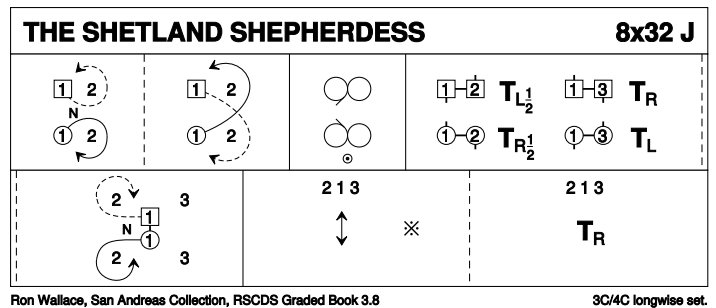

14 CHASING THE ECLIPSE S32 · 3/3L

Sandy Gallamore: *The Highland Road Collection* · Crib: SCDDDB Contributed Cribs & Diagrams · Diagram: Keith Rose's Diagrams

- 1-8 1C set, dance NH down the center + cast up to 2pl & cross to face 1cnr.
- 9-16 Reel 3 on sides - 1C pass 1cnr Rsh to begin.
- 17-24 1C+1cnr set, 1C spiral Rsh rnd ptrn to face 2cnr ; 1C+2cnr set, 1C spiral Rsh to face out 2pl own side.
- 25-32 All dance Chaperoned Chain Progression. End 3 1 2.

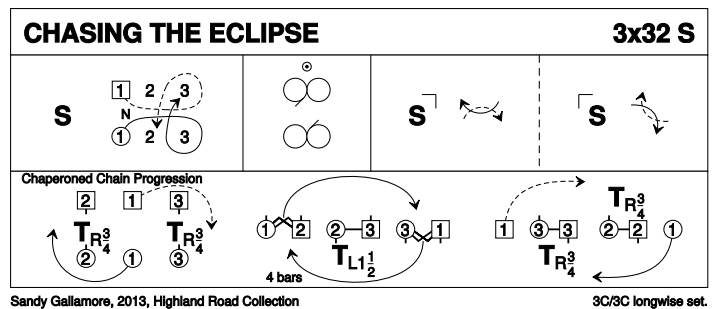

15 PARTY STREAMER J32 · 4/4L

Maria Elena Bonacini · Crib: E-cribs

- 1- 1c & 4c Fig8 round 2c/3c
- 9- 2c & 3c Fig8 round 1c/4c
- 17- 1c & 4c dance under arches by 2c & 3c | 1c dance under arch by 4c ; 2c+4c & 1c+3c turn on sides, 1c & 4c start out the ends
- 25- Circle8 & back (2,4,1,3)

16 THE HIGHLAND RAMBLER R40 · 3/4L

Roy Goldring: *Thirty Popular Dances, Volume Two* · Crib: E-cribs · Diagram: Keith Rose's Diagrams

- 1- 1c long cast to 2pl (2c up on [3-4] ; 1c+3c RHA (2,1,3)
- 9- 2c+1c LHA, 1W faces out ; 1W followed by 1M cast up round 2W and down the middle of set, 1W between 3c and 1M between 2c, all facing down
- 17- In lines of 3 down the middle (all swivel R) and up
- 25- 1M followed by 1W dance up, cast round 2W and into 2pl ; 1c turn RH
- 33- Circle6 and back

